

8

7

6

5

4

3

2

1

REVISIONS

EFFECTIVITY	REV	DESCRIPTION	DATE	APPROVED
FUTURE	A	REDRAWN TO BLUEPRINT FORMAT	5 / 18 / 99	

NOTES:

1. UNLESS OTHERWISE SPECIFIED:

A. BREAK EDGES .005.

B. SURFACE ROUGHNESS $32/\sqrt{\quad}$

$\triangle 2$ DASH NUMBERS INDICATE IN-HOUSE MACHINING OF THROAT DIAMETER.

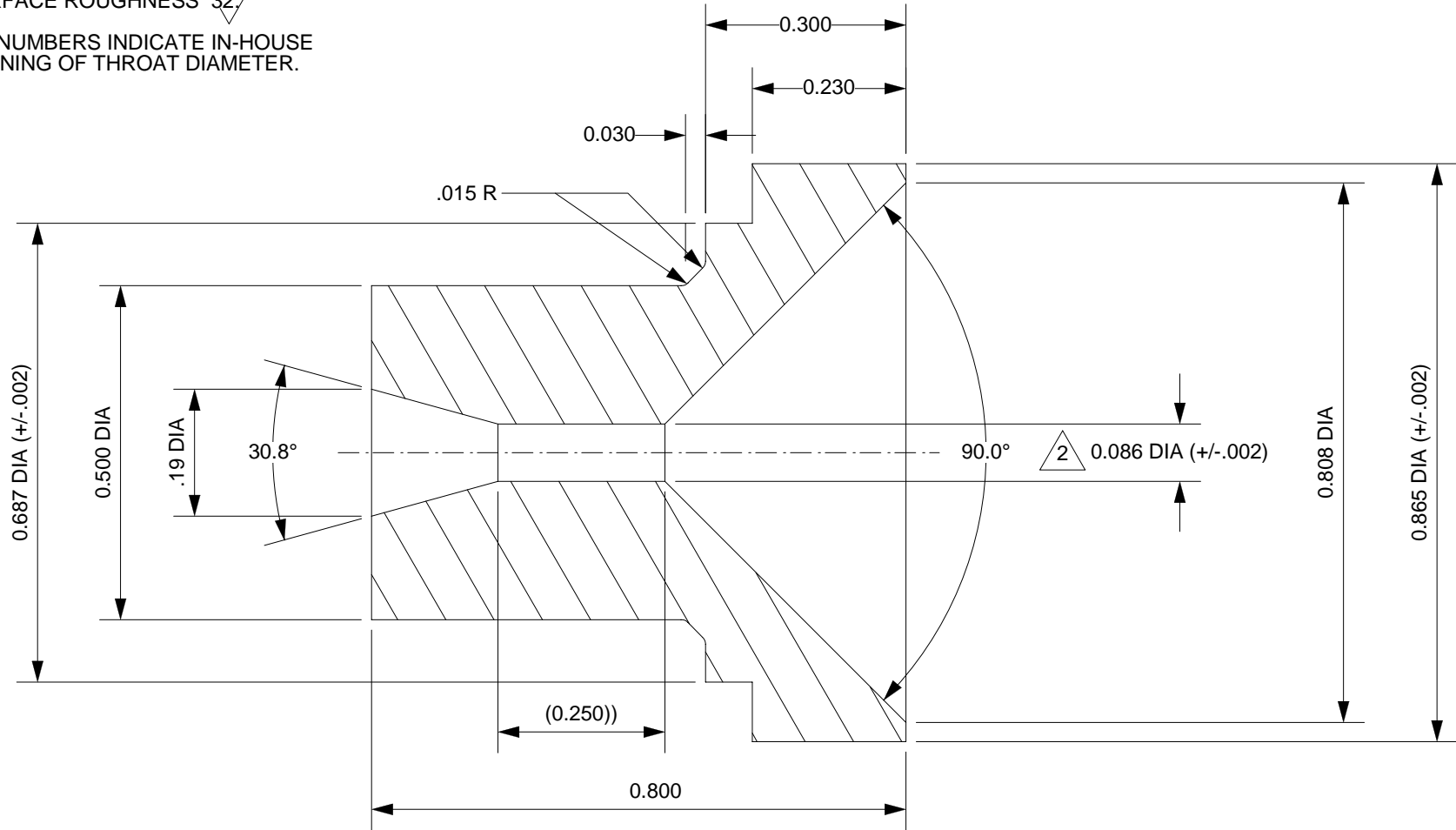

UNLESS OTHERWISE SPECIFIED DIMENSIONS ARE IN INCHES		QTY	01250-1	NOZZLE DRILLED .099" Dt	ITEM
		PART NUMBER		DESCRIPTION	
		LIST OF MATERIAL			
		CONTRACT NUMBER		2113 W. 850 N. Street Cedar City, Utah 84720 (435) 867-9998 (Ph) (443) 222-0203 (Fax)	
MATERIAL		PREP		E6/E15 .865 NOZZLE	
BLACK PHENOLIC (PROPRIETARY)		B. ROSENFELD		5 / 99	
FINISH		CHKR		SIZE NUMBER	
				A 01250	
				SCALE 4 / 1	
				SHEET 1 OF 1	

8

7

6

5

4

3

2

1