

8

7

6

5

4

3

2

1

REVISIONS

EFFECTIVITY	REV	DESCRIPTION	DATE	APPROVED
FUTURE	A	FIRST RELEASE ISSUE	11 / 10 / 04	

NOTES:

1. UNLESS OTHERWISE SPECIFIED:

A. BREAK EDGES .005.

B. SURFACE ROUGHNESS $32\sqrt{\text{in}}$

2. DASH NUMBERS INDICATE IN-HOUSE MACHINING OF THROAT DIAMETERS.

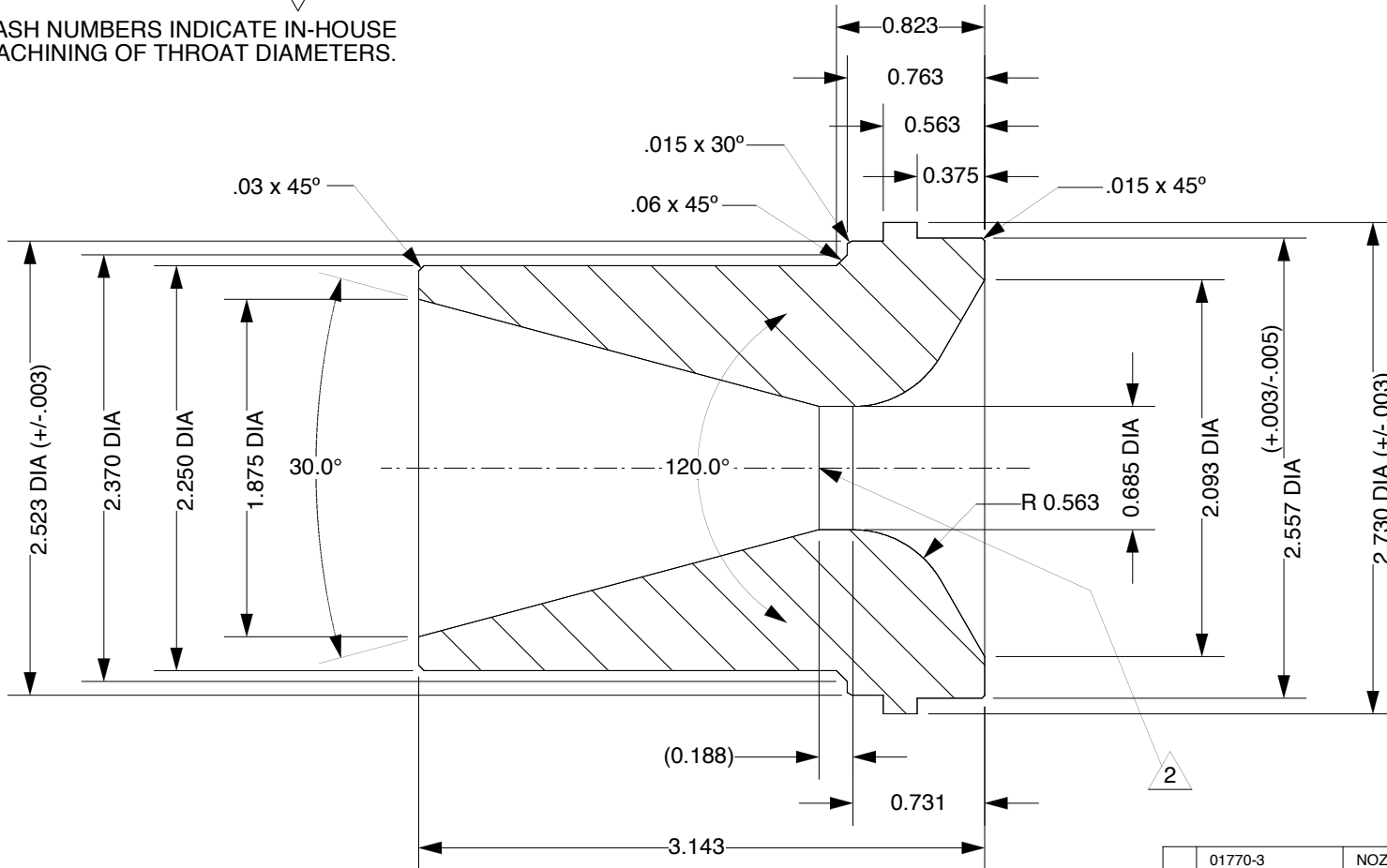

UNLESS OTHERWISE SPECIFIED DIMENSIONS ARE IN INCHES

.XX +/- .010	.XXX +/- .005	ANGLES +/- 2 deg.
-----------------	------------------	----------------------

MATERIAL
BLACK PHENOLIC
(PROPRIETARY)

FINISH

01770-3	NOZZLE DRILLED 1.000"		
01770-2	NOZZLE DRILLED .875"		
01770-1	NOZZLE DRILLED .769"		
QTY	PART NUMBER	DESCRIPTION	ITEM

LIST OF MATERIAL

CONTRACT NUMBER

RCS ROCKET MOTOR COMPONENTS, INC. 2113 W. 850 N. Street Cedar City, Utah 84720 (435) 865-7100 (Ph) (435) 865-7120 (Fax)

PREP B. ROSENFIELD 11 / 04

CHKR

APVD

APVD

SIZE **A** NUMBER **01770**

SCALE 1 / 1 SHEET 1 OF 1

8

7

6

5

4

3

2

1