

8

7

6

5

4

3

2

1

NOTES:

1. UNLESS OTHERWISE SPECIFIED:

A. BREAK EDGES .005.

B. SURFACE ROUGHNESS $32\sqrt{\text{ }}$

2. SAME AS RCS P/N 01800 KLMN NOZZLE EXCEPT AS NOTED FOR THROAT, ENTRANCE, AND EXIT DIMENSIONS.

REVISIONS

EFFECTIVITY	REV	DESCRIPTION	DATE	APPROVED
FUTURE	A	REDRAWN TO BLUEPRINT FORMAT	4 / 13 / 99	
FUTURE	B	REDESIGNED FOR NET MOLDED EXIT/THROAT	03 / 11 / 03	
FUTURE	C	120° ENTRANCE ANGLE VARIATION	8 / 15 / 05	

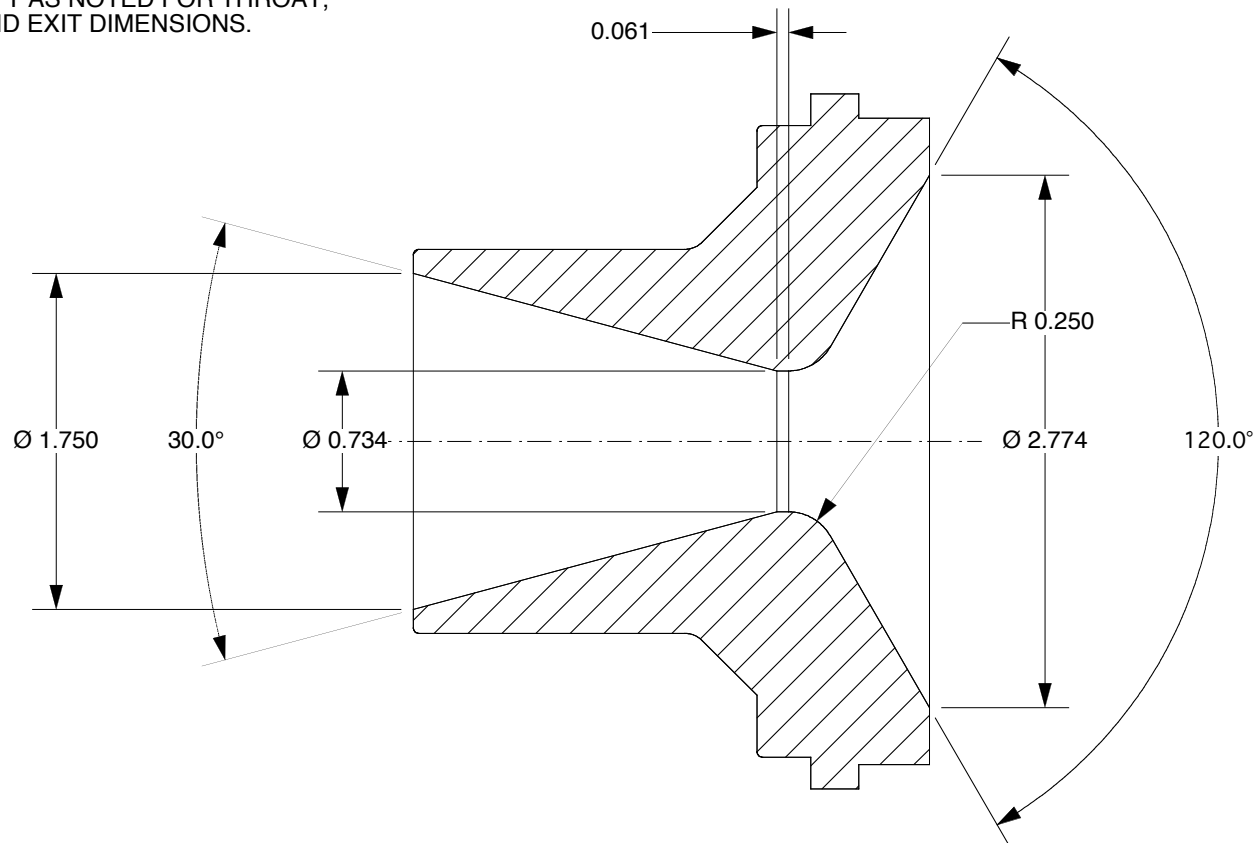

UNLESS OTHERWISE SPECIFIED DIMENSIONS ARE IN INCHES			QTY	PART NUMBER	DESCRIPTION	ITEM
.XX +/- .010	.XXX +/- .005	ANGLES +/- 2 deg.	LIST OF MATERIAL			
MATERIAL			CONTRACT NUMBER			
BLACK PHENOLIC (PROPRIETARY)			 2113 W. 850 N. Street Cedar City, Utah 84720 (435) 865-7100 (Ph) (435) 865-7120 (Fax)			
FINISH			PREP CHKR	B. ROSENFELD	8 / 05	KLMN MOLDED NOZZLE, WITH 1.750" EXIT / .734" THROAT
			APVD			SIZE A
			APVD			NUMBER 01800-3
			SCALE 1 / 1			SHEET 1 OF 1

8

7

6

5

4

3

2

1